

# PCV - Series RSR Pressure Relief Control Pinch Valve



- Opens incrementally as line pressure exceeds valve set pressure.
- Mitigates water hammer or cycling.
- Field adjustable.

The Red Valve Series RSR Pressure Relief Valve is designed specifically for slurry applications. It is a reliable relief valve available for slurry service, venting surge pressures in the system or to maintain system pressure. This valve is very beneficial when used to provide a fluid return path to a pump's sump when blockage is encountered.

The valve operates simply by using a spring-loaded cylinder which keeps a rugged, reinforced rubber pinch valve sleeve pinched closed. As process pressure builds up and exceeds the compressive force set by the spring, the valve opens. The greater the pressure build-up, the more the valve opens. The sleeve isolates the process from the pinch mechanism, eliminating corrosion, bridging, plugging and valve freezing.

The adjustment nut on top of the actuator allows for easy external recalibration. If actual system operation pressures change, the correction and fine-tuning of the system can be made by simply turning the adjustment nut.

## Materials of Construction

- **Body:** Ductile iron
- **Sleeves:** Pure Gum Rubber, Ethylene Propylene Diene Terpolymer (EPDM)\*, Acrylonitrile-Butadiene (NBR), Fluoroelastomer (FKM)\*, Chloroprene (CR)\*, Chlorosulfonated Polyethylene (CSM), Chloro-Isobutylene-Isoprene (CIIR).
- \* - White food grade options available.
- Drilled and tapped flanges: ASME 150, ASME B16.1 125 cast flanges.  
Other drill patterns available upon request.
- **Actuators:** Red Valve Fail Close.

## SERIES RSR

VALVE SIZE	DIMENSIONS in/mm		HEIGHT		WORKING PRESSURE psi/kPa
	LENGTH A	WIDTH B	C	D	
1" 25mm	7.25 184	6.00 152	Cylinder Height Based On Application	2.44 62	0-150 0-1030
1.5" 40mm	8.75 222	8.00 203		2.75 70	0-150 0-1030
2" 50mm	10.00 254	8.00 203		3.50 89	0-150 0-1030
2.5" 65mm	10.88 276	9.00 229		4.00 102	0-150 0-1030
3" 80mm	11.75 298	11.50 292		4.25 108	0-150 0-1030
4" 100mm	13.88 352	13.50 343		6.63 168	0-150 0-1030
6" 150mm	17.75 451	16.50 419		7.63 194	0-150 0-1030
8" 200mm	21.38 543	19.50 495		9.13 232	0-150 0-1030
10" 250mm	26.50 673	23.50 597		11.00 279	0-150 0-1030
12" 300mm	29.00 737	28.25 718		12.00 305	0-150 0-1030

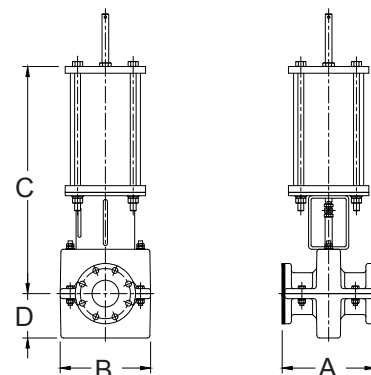

For critical dimensions, consult factory.