

Series D Knife Gate Valve

Installation, Operation and Maintenance Manual



The Red Valve Series D Knife Gate Valve is a 100% full bore, truly bi-directional valve designed for tough abrasive and general service applications. The Series D features heavy-duty elastomer seat cartridges which provide drop-tight closure and are replaced without any valve disassembly for ease of maintenance.

Flush ports are provided to allow the valve to be flushed with water and/or air. With a variety of actuators, limit switches, and other options available, the Series D can be built to fit your special applications.

IMPORTANT

Please take a moment to **review this manual. Before performing any maintenance on the valve be sure the pipeline has been de-pressurized.** The improper installation or use of this product may result in personal injury, product failure, or reduced product life. Red Valve Company, Inc. can accept NO liability resulting from the improper use or installation of this product. If you have any questions or problems, please call the customer service department at (412) 279-0044. We appreciate your comments. Thank you for choosing Red Valve.

INSTALLATION

1. When your order arrives, check the contents carefully to assure no damage or loss occurred in transit.
2. Check flange faces of pipe for rough/damaged areas. Pipeline flanges must be flat, properly spaced, and parallel to achieve proper seal. Do not mate Series D valves directly to expansion joints or other flexible connections. The ID of the mating pipe flange must not exceed the nominal steel pipe OD by .12" for sizes 12" and smaller, or .25" for sizes 14" and larger. Consult Red Valve if the flange ID exceeds these dimensions. Standard slip-on steel flanges meet the criteria. Slip-on adaptor flanges for ductile iron pipe can create a sealing problem.

The Series D can be used for end of line service if a flat face flange is bolted to the downstream side so that the downstream seat is retained. When the Series D is used to isolate equipment for future removal from the line, a spool piece needs to be installed between the valve and equipment if the end of line condition will result upon removal of the equipment.

NOTICE: Do not deflect the pipe-valve joint. Minimize bending stresses in the valve end connection with pipe loading.

If excessive seat leakage occurs during startup, check the installation and eliminate any distortion to the valve body.

3. The elastomer seat acts as a gasket and separate flange gaskets are normally not required. Installations where the mating flange has a "slick" surface may require a metal serrated or combination metal gasket serrated gasket and contractor supplied standard gasket materials to assist in creating a seal. All gaskets used on "low torque" flange material such as FRP and PVC should be approved by the pipe manufacturer for compatibility. Often the torque rating of the composite mating flange may be less than the minimum torque required to install the valve. Actuate valve to the full closed position for installation. Lubricate seat cartridges and gate liberally with a grease compatible with the seat material.
5. Insert seat cartridges. Flange gaskets are not required. Make sure that cartridges are of the correct size and properly centered on valve flange.
6. Installing Flange Bolts:

CAUTION: Only use flange bolts of the correct length in such manner that the bolts cannot bottom out in tapped holes. The use of bolts which are too long and bottom out in tapped holes can distort body, create a leak path and cause permanent valve damage. Red Valve recommends the use of studs in the chest area of the Series D in lieu of bolts.

Tighten each bolt uniformly on both sides of the valve (upstream and downstream side of the valve). This will distribute compression evenly on seat ring. Torque all the flange bolts and/or studs in a star pattern (as shown in Figure 1), first to 50% of tabulated values (See Figure 2), then retorque to 100% of tabulated values. If greater torque is required, continue retorquing in increments of 50% of tabulated values. Improper or uneven torqueing of flange bolts can cause premature seat cartridge failure and a leak between the mating flange and valve. Use of a high quality anti-seize compound on all bolt and/or stud thread is recommended.

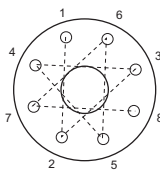

Figure 1

Nominal Valve Size	Flange Bolt Size	Bolt Length (w/ ASME 150# Flanges)	Minimum Bolt Torque (ft. pounds)
3"	5/8"-11	1.63	20
4"	5/8"-11	1.63	20
6"	3/4"-10	1.63	20
8"	3/4"-10	2.00	30
10"	7/8"-9	2.00	35
12"	7/8"-9	2.00	50
14"	1"-8	2.25	65
16"	1"-8	2.50	35
18"	1 1/8"-7	2.50	45
20"	1 1/8"-7	3.00	55
24"	1 1/4"-7	3.25	60
30"	1 1/4"-7	3.50	60
36"	1 1/2"-6	3.75	60

Figure 2: Installation Torque Specifications

7. Some leakage may occur at the packing when the line is pressurized. The factory does not tighten packing to overcome such leakage, as this can shorten packing life when valve is in storage. Simply tighten the packing nuts until the leakage stops.
8. Over tightening flange bolts to stop a leak can fracture or distort a composite flange such as an FRP or PVC flange. Steel back-up rings should be considered to try to seal a flange against a leak. Caution should be used to not over-torque FRP or PVC flanges when using steel back-up rings. Consult with the pipe and/or flange manufacturer.
9. Apply grease liberally to stem.

WARNING: Flush ports can be plugged or piped to a suitable drain. Removal of plug(s) will cause leakage of line materials. Consult your systems engineer for proper plumbing of flush port for your installation.

NOTICE: It is recommended that valves with actuators be installed in the vertical position. If actuated knife gates must be installed horizontally, it is recommended that the actuator be supported with a hanger or bracket.

OPERATION

Actuators

All actuators are furnished completely assembled and fully operational. All valve accessories and instrumentation are properly set and calibrated at the factory.

Manual Actuators

All handwheel, chainwheel, and bevel gear operators turn clockwise to close. The gate stops moving when the valve is fully opened or closed.

Chainwheel

Chainwheels can be furnished on both standard valves and valves with bevel gears. The chain must be fed through the guides and over the spokes around the outside diameter of the rim. The ends of the chain are then joined with a connecting link.

Electric Actuators

Electric Actuators come completely operational, with limit and torque switches set. Please refer to the individual actuator manuals for additional operation or maintenance information.

Cylinder Actuators

Cylinder Actuators operate from clean lubricated plant air. Cylinder Actuators are available in three basic configurations. Air-To-Open / Air-To-Close, Fail-Safe Open, and Fail-Safe Closed.

Air-to-Open/Air-to-Close (ATO/ATC)

A single 4-way valve is used to operate this standard cylinder style. The open-air supply is connected to the lower cylinder head, and close air source is attached to the upper cylinder. Each side of the cylinder must be vented when the other side of the cylinder is pressurized in order for the cylinder to function.

Fail-Safe Closed

A large diameter spring on the top of the cylinder piston provides the force to close this type of cylinder configuration. Air is only supplied to the bottom cylinder head for valve opening. The top cylinder head must remain vented at all times. When the bottom of the cylinder is pressurized with plant air, the valve opens. The valve will close automatically when the pressure is vented out of the bottom of the cylinder.

Fail-Safe Open

A large diameter spring on the bottom of the cylinder piston provides the force to open this type of cylinder configuration. Air is only supplied to the top cylinder head for valve closing. The bottom cylinder head must remain vented at all times. When the top of the cylinder is pressurized with plant air, the valve closes. The valve will open automatically when pressure is vented out through the top of the cylinder.

WARNING: Fail-safe cylinders contain large diameter springs in a compressed state. To avoid risk of serious injury, never attempt to disassemble fail-safe cylinders. Never cut, bend, or alter the protruding threads at the top of the cylinder. Fail-safe cylinders will actuate automatically with an interruption of supply air. To avoid risk of injury from unexpected actuation, always disconnect cylinder supply air and vent the air in the cylinder prior to inspecting, lubricating, or servicing valve.

WARNING

Water Hammer Effect: Too rapid of closure of any valve can create a forceful and potentially damaging water hammer effect. To minimize the risk of water hammer related damage, Red Valve recommends that the closure rate of the valve be controlled by restricting the exhaust rate of cylinder pressure. The addition of a needle valve having a reverse check in the cylinder head ports will enable you to smoothly control closure rate. Install so that air is free flow into the cylinder and controlled when exhausted.

MAINTENANCE

Valves should occasionally be inspected for damage and wear. The inspection period should be determined by the severity of the service and environment. Valves should be inspected every 90 days for normal applications, or more frequently for severe applications. If valves are periodically inspected and preventive maintenance done, the valve will last longer and operate better.

WARNING: Servicing the valve while the pipeline is under pressure can cause personal injury or equipment damage. Relieve pipeline pressure before servicing the valve.

Several items should be checked during inspection:

Check the stem for wear and any damaged threads. If threads are damaged, use a small file to remove small burrs on the thread.

Check the stem bushing for small pieces of metal which may have worn away. If excess material is noticed the stem bushing should be replaced.

Check the exposed portion of the gate when it is in the fully open position for excessive wear. If the gate is excessively worn, the gate should be replaced. Always keep the valve well lubricated and the gate free of excess buildup.

Resilient Seat Replacement

1. Make sure there is no pressure in the pipeline.
2. Remove the valve or remove all bolting except one bolt nearest the horizontal centerline and swing the valve out of the line.
3. Replace the seat cartridges and install the valve as described under installation.

Packing Replacement

1. Be sure that there is no pressure in the valve.
2. Close the valve. Disconnect the stem from the gate by removing the pin or bolts from the gate.
3. Raise the stem or piston rod. Open pressure must be maintained on fail close cylinders.
4. Remove the bolts from the packing stuffer. Remove the old packing. NOTE: Be careful not to damage the gate or lining.
5. Insert one ring of packing around the gate. Packing should be scarf cut (on a 45° angle), to make the packing seal better. Great care must be taken to make sure that the gate is flush against the seat. NOTE: If the packing is cut straight across, be sure that the ends of the packing butt together and do not overlap. Alternate the cut ends of the packing.
6. Tamp the packing to the bottom of the gland. Use a wood, plastic or brass rod and be sure not to scratch the gate or wall of the gland.

NOTE: Be sure that the gate is against the seat, and that packing contacts the wall of the gland and the gate all the way around.

7. Repeat steps 5 and 6 with another strip of packing. The end joints of the packing should be alternated to reduce the possibility of leakage.
8. Install the rubber secondary seal and push it to the bottom of the gland.
9. Repeat steps 5 and 6 with the third and final layer of packing.
10. Install the packing stuffer and tighten the bolts evenly. The bolts should not be completely tightened. Reconnect the gate to the actuator.
11. Operate the valve several times to break in the packing. Be sure that the gate is against the seat. Fully tighten the packing bolts.

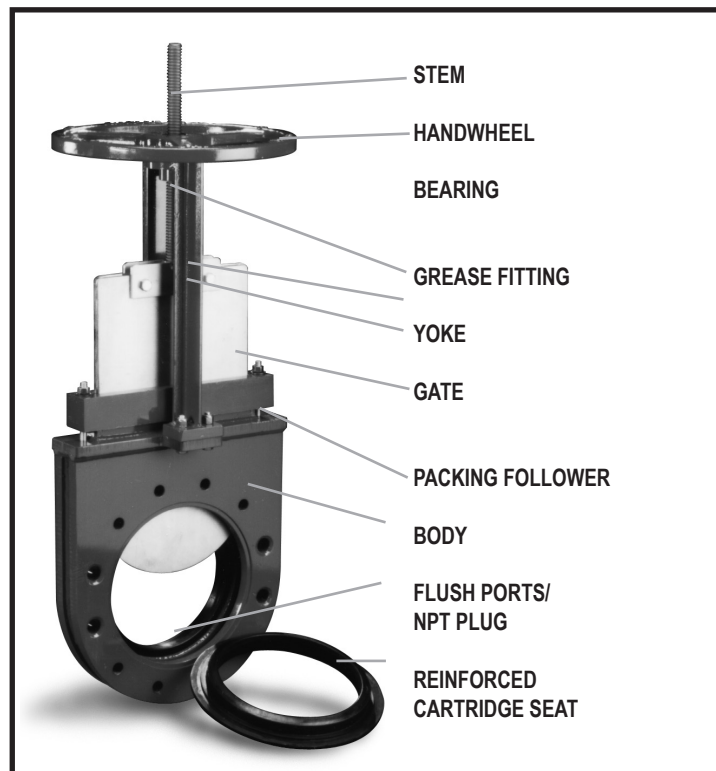

Figure 3: Red Valve Series D Knife Gate Valve Components

STORAGE

If your Series D Knife Gate Valve is to be stored for a period of time prior to installation, the following storage guidelines will help preserve your valve and assure a trouble free installation.

1. Store resilient seat cartridges in a clean, cool and dry location. Avoid exposure to light, electric motors, dirt or chemicals.
2. Store valve in a clean, dry location. Make certain that valve and actuator are well supported. Do not stack other items on valve.
3. Grease stem, gate, and flange holes liberally to inhibit corrosion.

MAKE CERTAIN THAT SEAT CARTRIDGES AND THIS MANUAL ARE STORED AND READILY AVAILABLE AT TIME OF INSTALLATION.

Lifting the valve improperly may damage it. Do not fasten lifting devices to piping or attached components. Lift the valve with slings, chains or cables fastened around the valve body, or fastened to bolts or rods through bolt holes in the flanges.

TROUBLESHOOTING

Condition	Possible Cause	Corrective Action
Valve binds or difficulty turning handwheel.	Burrs or wear on the stem and/or bushing	Remove burrs, replace damaged or worn parts.
	Build-up on gate.	Clean gate and remove build-up, flush body.
	Stem and gate need lubricant.	Lubricate stem and gate.
	Seat cartridge is damaged.	Replace seat cartridge.
	In-line obstruction exists.	Remove obstruction.
Valve leaks at packing.	Packing gland is loose.	Tighten packing gland.
	Packing is damaged.	Replace packing.
Valve does not check flow when closed.	In-line obstruction exists.	Remove obstruction.
	There is build-up, wear, or damage to the gate or seat cartridge.	Remove build-up, replace damaged parts.
Resilient seat cartridges are softened or deteriorated.	Pipeline media is not chemically compatible with resilient seat material.	Contact Red Valve.



Limited Warranty

Red Valve Company ("Seller") manufactured products, auxiliaries and parts thereof that we manufacture for a period of twenty-four (24) months from date of shipment from Seller's factory, are warranted to the original purchaser only against defective workmanship and material, but only if properly stored, installed, operated, and serviced in accordance with Seller's recommendations and instructions.

For items proven to be defective within the warranty period, your exclusive remedy under this limited warranty is repair or replacement of the defective item, at Seller's option, FCA Incoterms 2020 Seller's facility with removal, transportation, and installation at your cost.

Products or parts manufactured by others but furnished by Seller are not covered by this limited warranty. Seller may provide repair or replacement for other's products or parts only to the extent provided in and honored by the original manufacturer's warranty to Seller, in each case subject to the limitations contained in the original manufacturer's warranty.

No claim for transportation, labor, or special or consequential damages or any other loss, cost or damage is being provided in this limited warranty. You shall be solely responsible for determining suitability for use and in no event shall Seller be liable in this respect.

This limited warranty does not warrant that any Seller product or part is resistant to corrosion, erosion, abrasion or other sources of failure, nor does Seller warrant a minimum length of service.

Your failure to give written notice to us of any alleged defect under this warranty within twenty (20) days of its discovery, or attempts by someone other than Seller or its authorized representatives to remedy the alleged defects therein, or failure to return product or parts for repair or replacement as herein provided, or failure to store, install, or operate said products and parts according to the recommendations and instructions furnished by Seller shall be a waiver by you of all rights under this limited warranty.

This limited warranty is voided by any misuse, modification, abuse or alteration of Seller's product or part, accident, fire, flood or other Act of God, or your failure to pay entire contract price when due.

The foregoing limited warranty shall be null and void if, after shipment from our factory, the item is modified in any way or a component of another manufacturer, such as but not limited to; an actuator is attached to the item by anyone other than a Seller factory authorized service personnel.

All orders accepted shall be deemed accepted subject to this limited warranty, which shall be exclusive of any other or previous warranty, and this shall be the only effective guarantee or warranty binding on Seller, despite anything to the contrary contained in the purchase order or represented by any agent or employee of Seller in writing or otherwise, notwithstanding, including but not limited to implied warranties.

THE FOREGOING REPAIR AND REPLACEMENT LIMITED WARRANTY IS IN LIEU OF ALL OTHER WARRANTIES, OBLIGATIONS AND LIABILITIES, INCLUDING, BUT NOT LIMITED TO, ALL WARRANTIES OF FITNESS FOR A PARTICULAR PURPOSE OR OF MERCHANTABILITY OR OTHERWISE, EXPRESSED OR IMPLIED IN FACT OR BY LAW, AND STATE SELLER'S ENTIRE AND EXCLUSIVE LIABILITY AND YOUR EXCLUSIVE REMEDY FOR ANY CLAIM IN CONNECTION WITH THE SALE AND FURNISHING OF SERVICES, GOODS OR PARTS, THEIR DESIGN, SUITABILITY FOR USE, INSTALLATION OR OPERATIONS. NEITHER ANY PERFORMANCE OR OTHER CONDUCT, NOR ANY ORAL OR WRITTEN INFORMATION, STATEMENT, OR ADVICE PREPARED BY SELLER OR ANY OF OUR EMPLOYEES OR AGENTS WILL CREATE A WARRANTY, OR IN ANY WAY INCREASE THE SCOPE OR DURATION OF THIS LIMITED WARRANTY.

Limitation of Liability

IN NO EVENT SHALL SELLER BE LIABLE FOR ANY DIRECT, INDIRECT, SPECIAL, PUNITIVE, EXEMPLARY, OR CONSEQUENTIAL DAMAGES (INCLUDING, BUT NOT LIMITED TO, DAMAGE TO OR LOSS OF OTHER PROPERTY OR EQUIPMENT, BUSINESS INTERRUPTION, COST OF SUBSTITUTE PRODUCTS, LOSS OF TIME, LOSS PROFITS OR REVENUE, COST OF CAPITAL, LOSS OF USE, OR DIMINUTION IN VALUE) WHATSOEVER, AND SELLER'S LIABILITY, UNDER NO CIRCUMSTANCES, WILL EXCEED THE CONTRACT PRICE FOR THE GOODS AND/OR SERVICES FOR WHICH LIABILITY IS CLAIMED. ANY ACTION FOR BREACH OF CONTRACT BY YOU, OTHER THAN RIGHTS RESPECTING OUR LIMITED WARRANTY DESCRIBED ABOVE, MUST BE COMMENCED WITHIN 12 MONTHS AFTER THE DATE OF SALE.

Sales and Service

For information about our worldwide locations, approvals, certifications and local representative:

Web site: RedValve.com E-Mail: support@redvalve.com



750 Holiday Drive, Suite 400, Pittsburgh, PA 15220 • Phone: 412-279-0044

Red Valve Company reserves the right to incorporate our latest design and material changes without notice or obligation. Design features, materials of construction and dimensional data, as described in this manual, are provided for your information only and should not be relied upon unless confirmed in writing by Red Valve Company. Certified drawings are available upon request.